

GENERAL DESCRIPTION

The GPS distribution system acts as a low loss extender between the GPS antenna and GPS receiver in places where signals are otherwise unavailable, or running long coaxial lines is impractical. Optical Zonu (OZC) offers a complete GPS distribution system, based upon its RF over Fiber (RFoF) technology, with the capability to connect up to 32 remote sites from a single GPS antenna using only a single 1U chassis based Master Unit. The platform for the GPS distribution system is the OZC low profile, hot-swappable and modular J-Series system. It is an ideal solution for providing GPS timing and reference signals over fiber optic cable. The OZC GPS distribution system provides power to the antenna utilizing its built-in Bias-T and low noise distribution amplifier for high sensitivity detection of low level GPS signals.

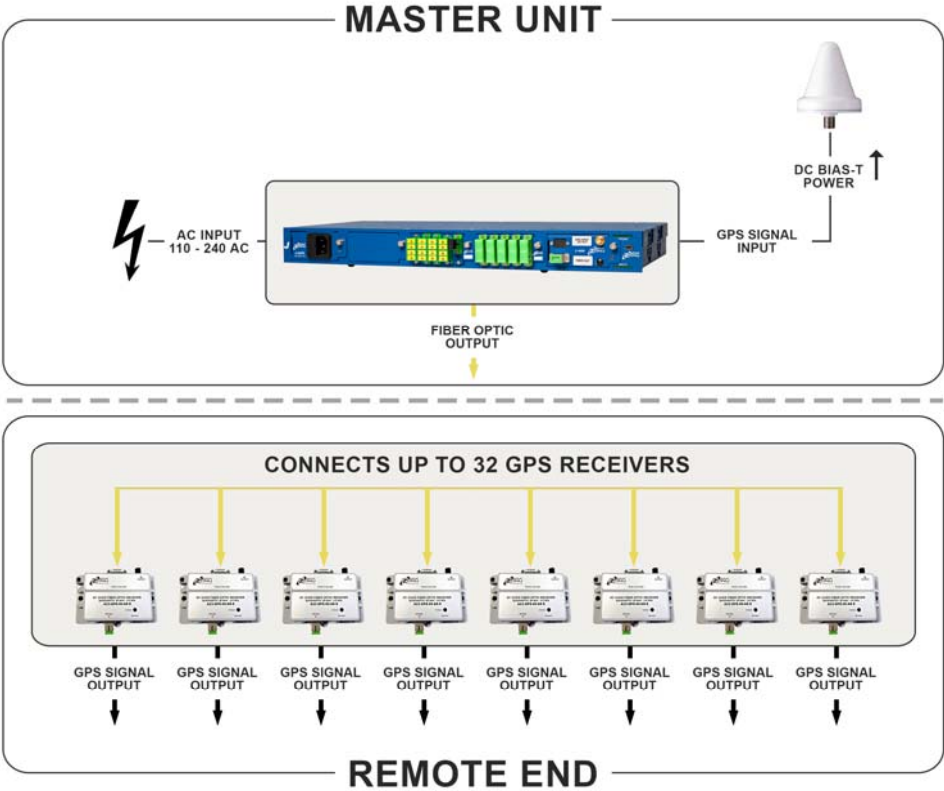

The GPS links can pass through end-to-end bandwidths of 20 MHz to 3 GHz, but are designed for low noise optical fiber links and optimized for GPS satellite bands between 1 GHz to 2 GHz. Our GPS over RFoF technology makes it possible to transmit GPS timing signals safely and securely over long distances (15 Km or more) with very little loss. GPS over RFoF technology inherently provides electrical isolation between the GPS antenna and the expensive receiver equipment to provide protection from lightning strikes.



GPS FIBER OPTIC DISTRIBUTION SYSTEM



The GPS Fiber Optic Distribution system is used to transport GPS signals from a single antenna to as many as 32 GPS receivers (or multiple antennas to multiple receivers). A common example of this application is a campus scenario where installing multiple GPS antennas is impractical. This particular system consists of the OZC J-Series 5-Slot modular 1U chassis. The Master Unit is located within close proximity of the GPS antenna and it contains modular and hot-swappable fiber optic transmitter, AC power supply and J Optical Splitter cards. The remote unit is a stand-alone (wall mountable) unit. It comes in a low profile semi-rugged package. A single 1U chassis at the master site is capable of supporting up to 32 remote locations. The optical transmitter module has built-in LNA for high sensitivity detection of low level GPS signals. The Master Unit also has a Bias-T to provide DC power to the GPS Antenna. Local monitoring is also integrated into the Master Unit, which is accessible via a single computer interface terminal.

The maximum RF input signal into the transmitter is -25 dBm and the RF interface is via a 50 Ohms SMA connector. The standard optical connector is SC/APC (FC/APC is also available upon request) for low back reflection applications. The system is designed to operate on single mode fiber but may be custom configured to work on multimode fiber. Please contact the Factory for more details.

The system is configured for complete dual redundancy, including additional fiber optic Tx module for a second GPS antenna.

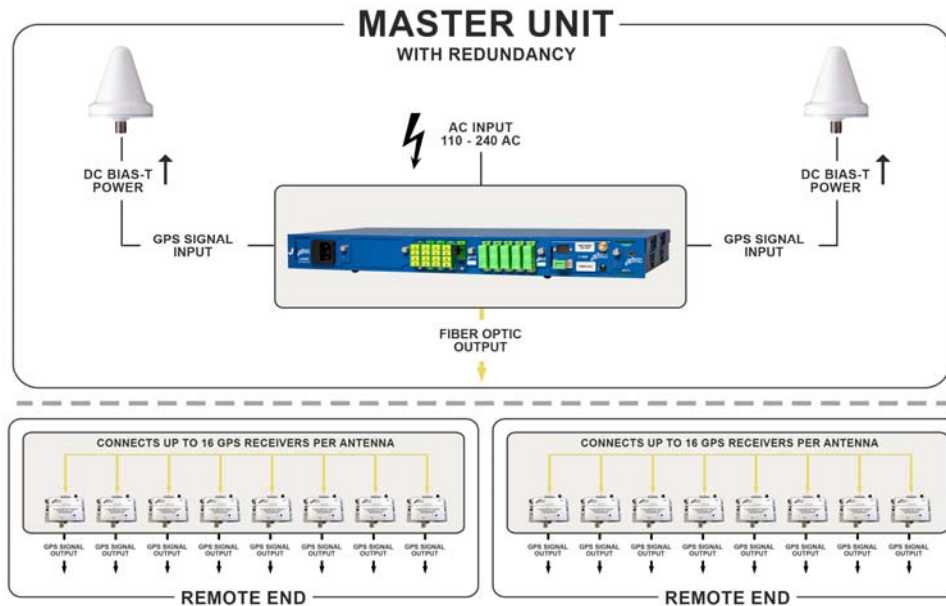

SYSTEM SPECIFICATION

Frequency Range	1 GHz – 2 GHz.
Noise Figure P2P	3.3 dB (GPS antenna Gain not included)
IIP3	-10dBm
Link Gain	42 dB (GPS antenna Gain not included)
Group Delay	< 1nS
Fiber Optic Cable	~5 nS for 1m fiber optic cable
Power	Master Unit: 110 -240V AC or -48VDC
RF Connector	50 Ohm SMA
Bias-T Option	+5V or +12V
Fiber Optic	SC/APC (LC/APC or FC/APC are optional)

ENCLOSURES

Master Unit	1U Modular Chassis 19" x 1U x 8
Remote Unit	Stand Alone Box 3" x 1.5" x 5"
Weight (Master Unit)	3.6 kg
Weight (Remote)	0.3 kg

MULTI-PORT DISTRIBUTION SYSTEM SPECIFICATIONS WITHOUT GPS ANTENNA GAIN

NUMBER OF OPTICAL RX	NF (dB)	GAIN (dB)
1	3.3	42
2	4.4	35
4	8.6	26.5
8	12.4	21.7
16	19.5	14.2
32	24	7.5

ORDERING INFORMATION

NO.	PART NUMBER	DESCRIPTION
1	A13-GPS-J8-AS-S	Master Unit Supports 8 Remote Modules – SC/APC (Optical) and 50 Ω SMA (RF)
2	A13-GPS-J16-AS-S	Master Unit Supports 16 Remote Modules – SC/APC (Optical) and 50 Ω SMA (RF)
3	A13-GPS-J32-AL-S	Master Unit Supports 32 Remote Modules – LC/APC (Optical) and 50 Ω SMA (RF)
4	A23-GPS-00-AS-S	Remote Unit -1 Fiber Optic Receiver – SC/APC (Optical) and 50 Ω SMA (RF)
5	350-1212-02	AC to DC power supply for Remote Unit
6	A113-GPS-J8-AS-S	Master Unit for 2 GPS Antennas and 8 Remotes per – SC (Optical) & 50 Ω SMA (RF)
7	A113-GPS-J16-AS-S	Master Unit for 2 GPS Antennas and 8 Remotes per – SC (Optical) & 50 Ω SMA (RF)
8	A23-GPS-00-AS-M	Multi-mode Fiber Compatible Remote Unit – SC/APC (Optical) and 50 Ω SMA (RF)

Note: Please contact Sales for additional optical or RF connector options and different installation configurations involving multiple receivers.

OPTIONS

- The Master Unit monitors the current drawn by the antenna to confirm proper operation.
- On the remote, the module provides switchable current load for the GPS receiver. This feature provides alarming function in case the GPS antenna is not connected properly at the antenna site. In case there is an issue with the GPS antenna the Current load will disappear alerting the GPS receiver equipment.

